

User Guide

CNB1

Counter Top Drinking Water Filter System

Puretec Customer Service

Thank you for purchasing a Puretec Basic Counter Top drinking water system. Your system is a proven performer manufactured from only quality materials and components and will give years of 'spring fresh' water free of impurities if maintained properly.

The system is designed for metropolitan supply water but can be used in other situations. For other types of water supply please contact your local Puretec stockist.

The Puretec filter system's cartridges need replacing regularly to maintain optimum performance. This is a simple procedure when following instructions. For cartridge replacements contact your stockist.

Operation

The Puretec Basic Counter Top systems are designed to run economically for many years and this is dependant on the initial installation and periodical maintenance.

To initiate purified water delivery, turn on kitchen tap then pull the pin on the diverter. To stop it push the pin back in. NOTE: Turn water on slowly.

Important: Use cold water only.

Flush systems for 10 minutes after any period of non-use more than 2 days.

For a period of non-use of 2 weeks or more, it may be necessary to replace cartridges.

Caution: Do not use with water that is microbiologically unsafe or with water of unknown quality without adequate disinfection before or after the system.

Cartridge Replacement

To maintain the high quality of the purified water the cartridges need changing every 6 months (this is dependant on water quality and usage).

You can obtain replacement cartridges from your dealer and to maintain performance, warranty use genuine Puretec replacements.

Cartridge Installation/Changeout

To change the filter cartridge please adhere to the following procedure.

1. Ensure kitchen tap is off and then turn filter system upside down while changing filter.
2. Unscrew the filter bowl. If difficult to undo, a wrench may be purchased to make it easier. Remove old cartridge.
3. Clean bowl with soap and warm water and rinse thoroughly. Check O-Ring for damage and if there is any, replace.
4. Check O-Ring lubrication and if necessary apply a light coating of food grade silicone lubricant or similar.

5. Remove all packaging from the new filter cartridge and insert into housing bowl making sure that it is properly seated over spigot in the base of the bowl. Where present, ensure that the arrow on the filter cartridge is pointing towards the head of the housing
6. Hold bowl upright while screwing onto head. Make certain that the spigot in the housing head is located centrally to the cartridge to make a good seal. Hand tighten bowl until firm - DO NOT OVER TIGHTEN.
7. Allow water to run for 2 minutes to flush the system.
8. Check for leaks. Flush system for 10 minutes after any period of non-use more than 2 days. For a period of non-use of 2 weeks or more, it may be necessary to replace the cartridge.

Installation

1. Remove existing aerator from your kitchen top.
2. Screw the diverter valve onto the thread of the tap using a small amount of thread seal tape. If your tap has a female thread use the male adaptor provided.
3. Check for leaks; if necessary use vise grips to tighten adaptor.
4. Turn on cold water tap and pull the pin on the divertor outward.
5. Water can now be diverted either through the filter or the regular tap simply by turning the lever.
6. Let water run for 15 minutes to flush the system. Air bubbles may be present for a short period.

Parts Diagram

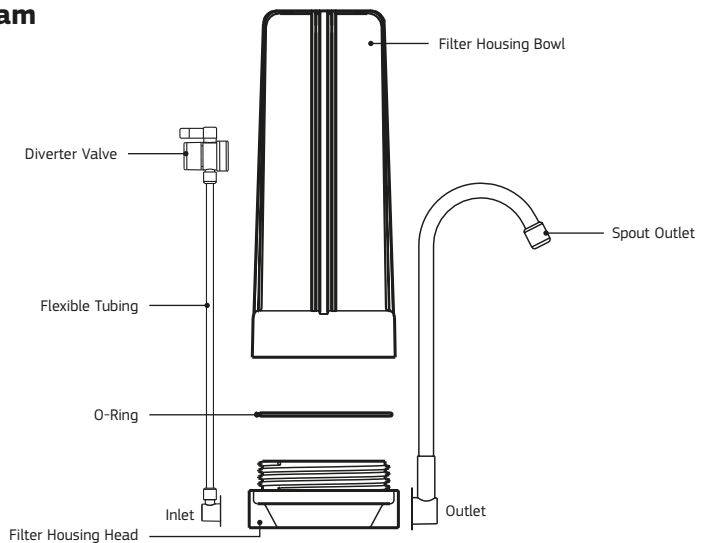

Warranty

Any claim under this warranty must be made within 1 year of the date of purchase of the product. This product is warranted to be free of defect of material and workmanship for 1 year from date of purchase. Puretec is renowned for its quality and after-sales support so if you have any issues please call 1300 140 140 (AU) or 0800 130 140 (NZ). To make a warranty claim, contact us directly or the place of original purchase. All costs relating to a warranty claim must be approved by Puretec prior to any work being carried out. 1 year warranty is 1 year parts and labour. Excludes cartridges.

Puretec will pay your reasonable, direct expenses of claiming under this warranty. You may submit details and proof of your expense claim to place of purchase for consideration.

The warranty only applies if the product was used and/or installed in accordance with the user guide and/or installation instructions. This warranty is given in lieu of all other express or implied warranties and manufacturer shall in no circumstance be held liable for damages consequential or otherwise or delays caused or faulty manufacturing except as excluded by law.

Applicable to all above, is that the warranties need to be approved by Puretec to ensure product was not incorrectly used, installed or claimed. False and incorrect claims will be pursued at Puretec's discretion, including chargeable inspection and labour costs incurred.

Warranty/Australia

This warranty is given by Puretec Pty Ltd, ABN 44 164 806 688, 37-43 Brodie Road, Lonsdale SA 5160, telephone no. 1300 140 140 and email at sales@puretec.com.au.

This warranty is provided in addition to other rights and remedies you have under law: Our goods come with guarantees which cannot be excluded under the Australian Consumer Law. You are entitled to replacement or refund for a major failure and to compensation for other reasonably foreseeable loss or damage. You are also entitled to have the goods repaired or replaced if the goods fail to be of acceptable quality and the failure does not amount to a major failure.

Warranty/New Zealand

This warranty is given by Puretec NZ LP, Reg. No 50081773, PO Box 875 Cambridge 3450 NZ, telephone no. 0800 130 140 and email at sales@puretec.co.nz.

This warranty is provided in addition to other rights and remedies you have under law: Our goods come with guarantees which cannot be excluded under the Consumer Guarantees Act. You are entitled to replacement or refund for a major failure and to compensation for other reasonably foreseeable loss or damage. You are also entitled to have the goods repaired or replaced if the goods fail to be of acceptable quality and the failure does not amount to a major failure.

**AUSTRALIA**

P 1300 140 140

E sales@puretec.com.auW puretec.com.au**NEW ZEALAND**

P 0800 130 140

E sales@puretec.co.nzW puretec.co.nz